

ISOMAG ™

The friendly magmeter

MS 600

POLYPROPYLENE SENSOR



**LIGHT "WEIGHT" SENSOR COMPLETELY IN
POLYPROPYLENE**

The manufacturer guarantees only English text.
Available on our web site: www.isomag.eu

ISOIL 
INDUSTRIA
The solutions that count

INDEX

TECHNICAL DATA	3
OVERALL FEATURES.....	3
STANDARD FEATURES.....	3
OPTIONAL FEATURES.....	3
OVERALL DIMENSIONS.....	4
INSTALLATION RECOMMENDATIONS	5
SENSOR GROUNDING.....	6
SEPARATE VERSION.....	7
PRESSURE LOSS CALCULATION	8
(CONES 8° ANGLES).....	8
HOW TO ORDER	9

TECHNICAL DATA

<i>OVERALL FEATURES</i>	
Nominal diameter	<input type="checkbox"/> DN 3 ÷ 20
Minimum conductivity	<input type="checkbox"/> 5 µS/cm
Humidity Range	<input type="checkbox"/> 0÷100% (IP 67)
Accuracy	<input type="checkbox"/> See relevant converter data sheet
CE Certification	<input type="checkbox"/> Yes

<i>STANDARD FEATURES</i>	
Body material	<input type="checkbox"/> Polypropylene
Nominal pressure	<input type="checkbox"/> 1600 kPa
Process connection	<input type="checkbox"/> Threaded UNI 338 <input type="checkbox"/> Threaded NTP
<i>Version – protection rating</i>	<input type="checkbox"/> Compact IP67
Connections material	<input type="checkbox"/> Polypropylene
Lining material	<input type="checkbox"/> Polypropylene
Gasket material	<input type="checkbox"/> FPM
Liquid temperature	<input type="checkbox"/> - 0°C ÷ 60°C
Vacuum resistance	<input type="checkbox"/> 10 Kpa absolute at 60 °C
Electrodes material	<input type="checkbox"/> Stainless steel AISI 316 <input type="checkbox"/> Hastelloy C <input type="checkbox"/> Platinum-rhodium <input type="checkbox"/> Titanium <input type="checkbox"/> Tantalum

<i>OPTIONAL FEATURES</i> (CHECK FOR MORE DETAILS 'HOW TO ORDER' ON LAST PAGE)	
Gasket material	<input type="checkbox"/> EPDM
Process connection	<input type="checkbox"/> Other on request
Electrodes material	<input type="checkbox"/> On request
Version – protection rating	<input type="checkbox"/> Separate (max 20m) – IP 68 <input type="checkbox"/> Separate (max 500m) with pre-amp IP 67 (IP 68 optional)

OVERALL DIMENSIONS

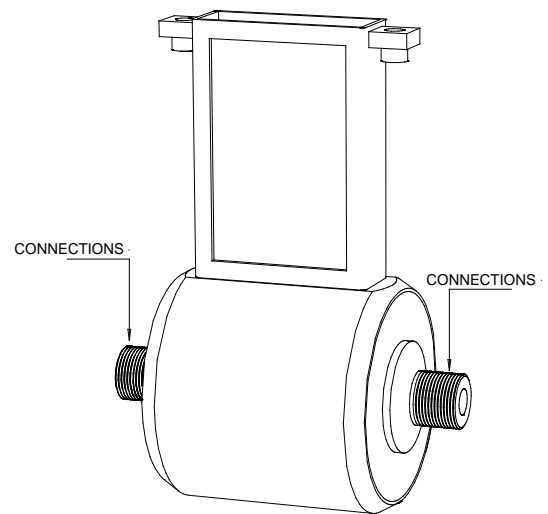
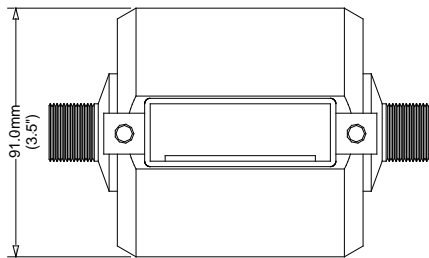
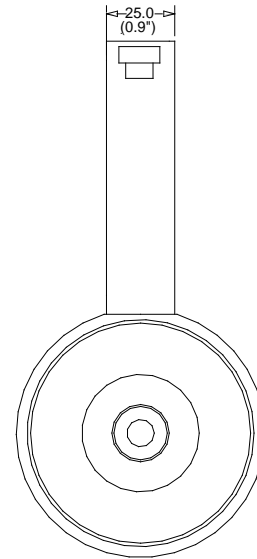
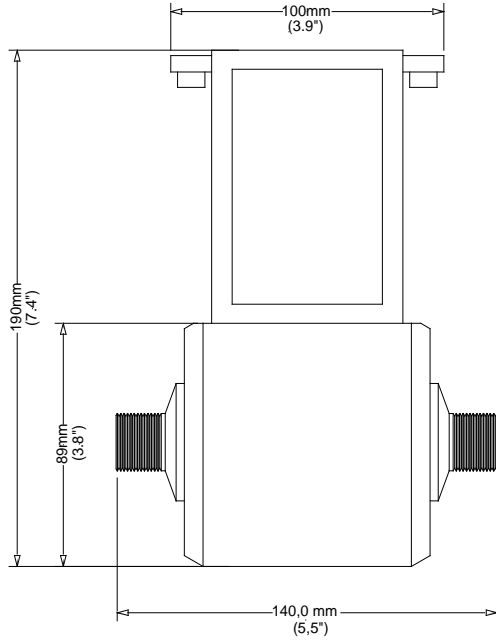

CONNECTIONS GAS/NPT

DIMENSIONS mm (inches)	DN				
	3 (1/8")	6 (1/4)	10 (3/8)	15 (1/2")	20 (3/4")
CONNECTIONS	1/4"	3/8"	1/2"	3/4"	1"

INSTALLATION RECOMMENDATIONS

In vertical installations an ascending flow is preferable. For vertical installations with descending flow direction contact the manufacturer

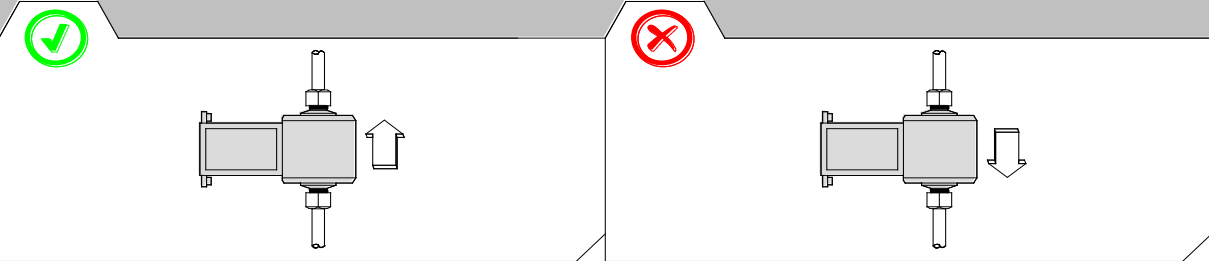

For installations in long pipe lines, please use anti vibration joints

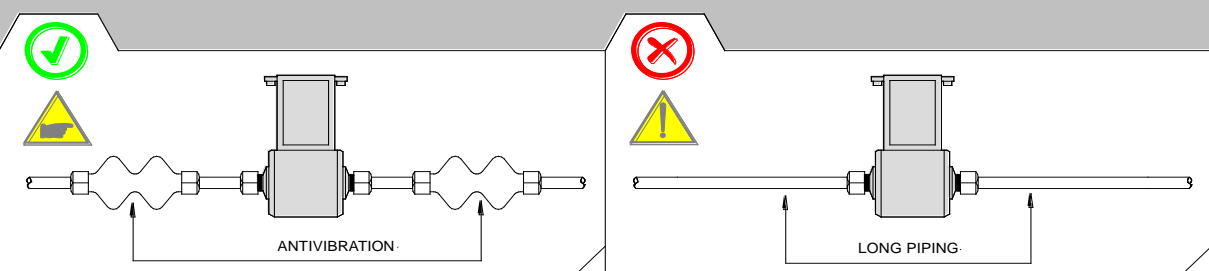

Avoid a partially empty pipe, during operation the pipe must be either completely full of liquid or completely empty

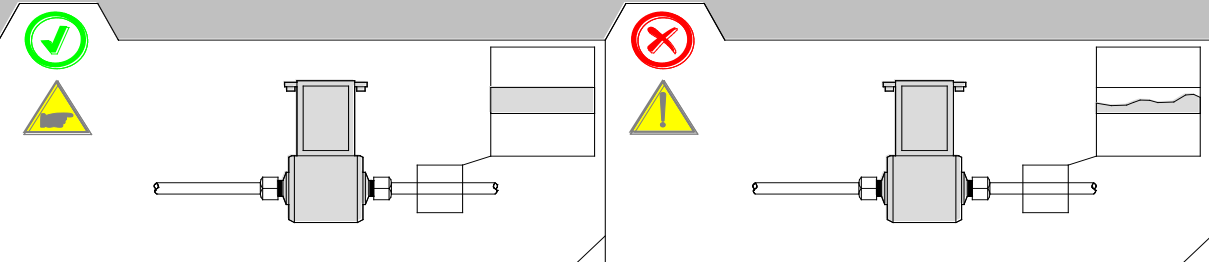

Install the sensor away from bends and hydraulic accessories and hydraulic accessories

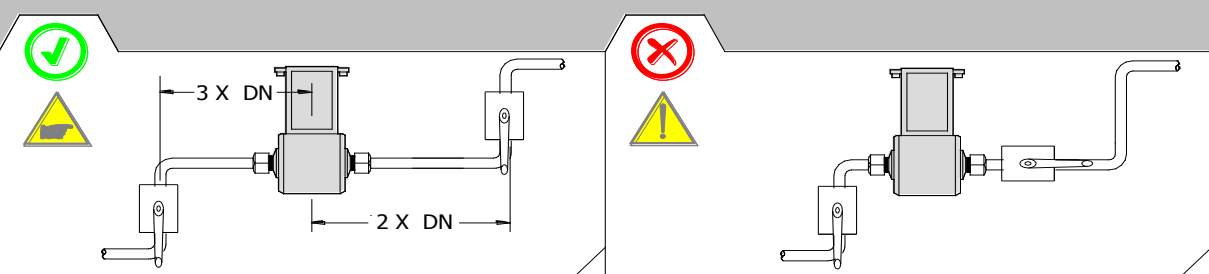

Avoid positioning flange and counter flanges by tightening the nuts.

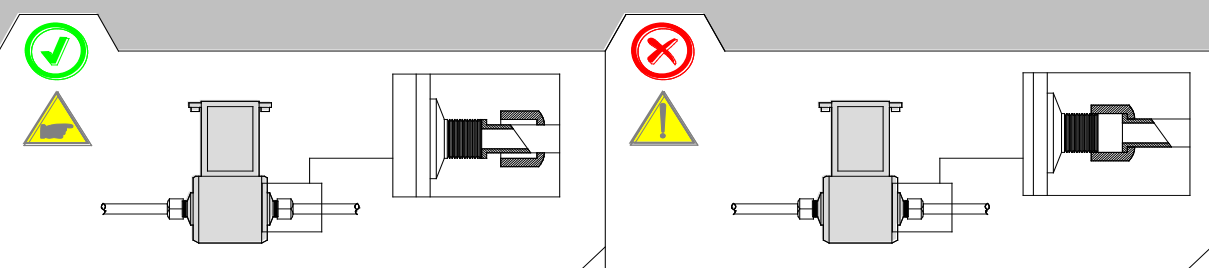

SENSOR GROUNDING

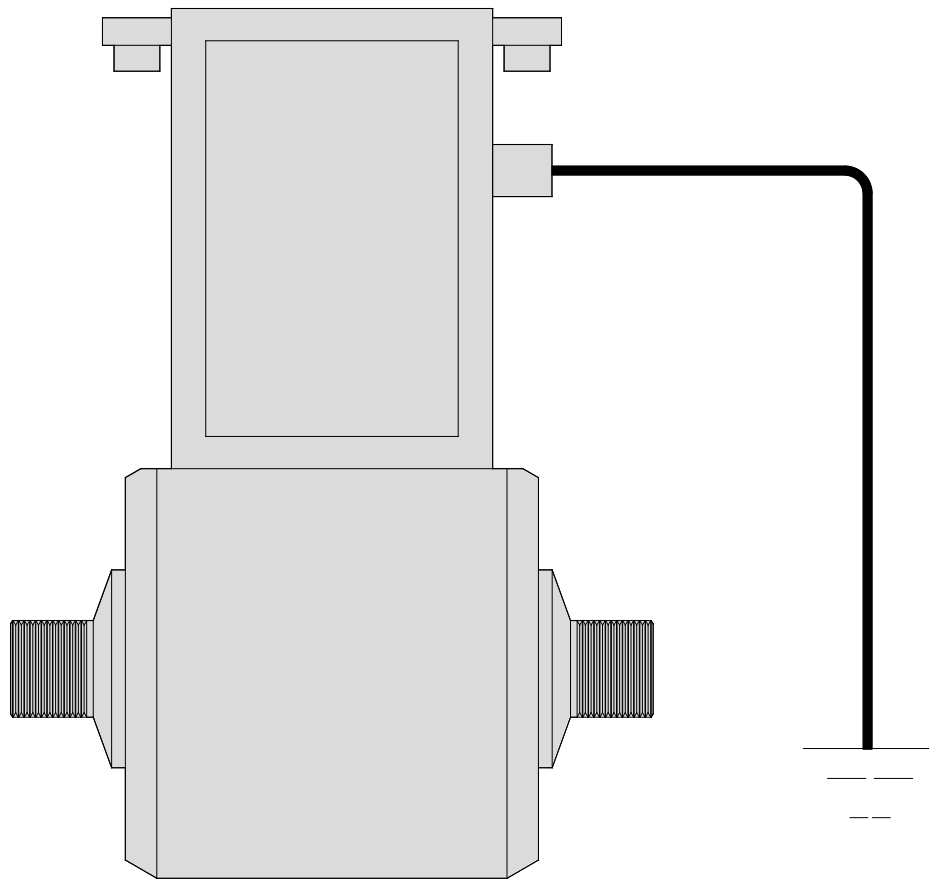

For the correct operation of the meter the sensor and liquid must be equipotential. ALWAYS connect sensor and converter to the ground.

SEPARATE VERSION

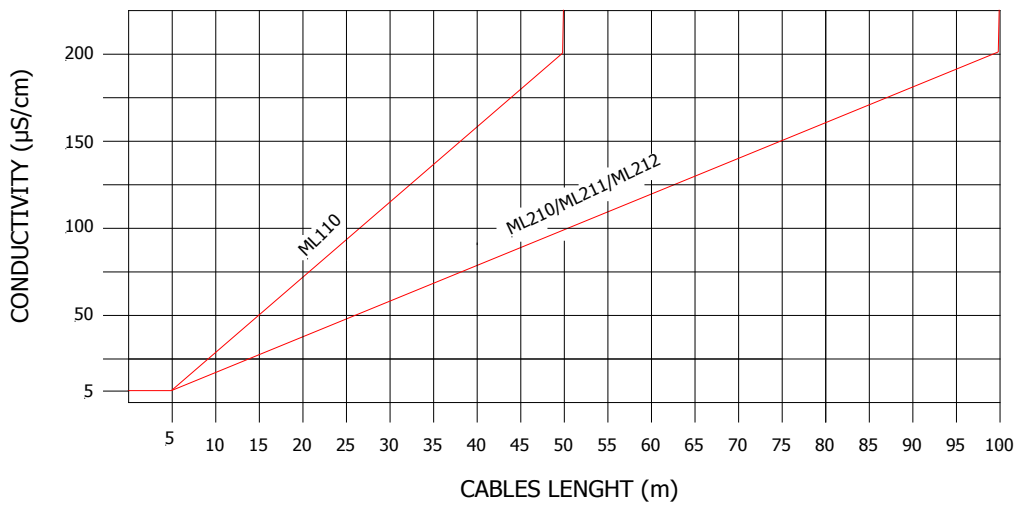
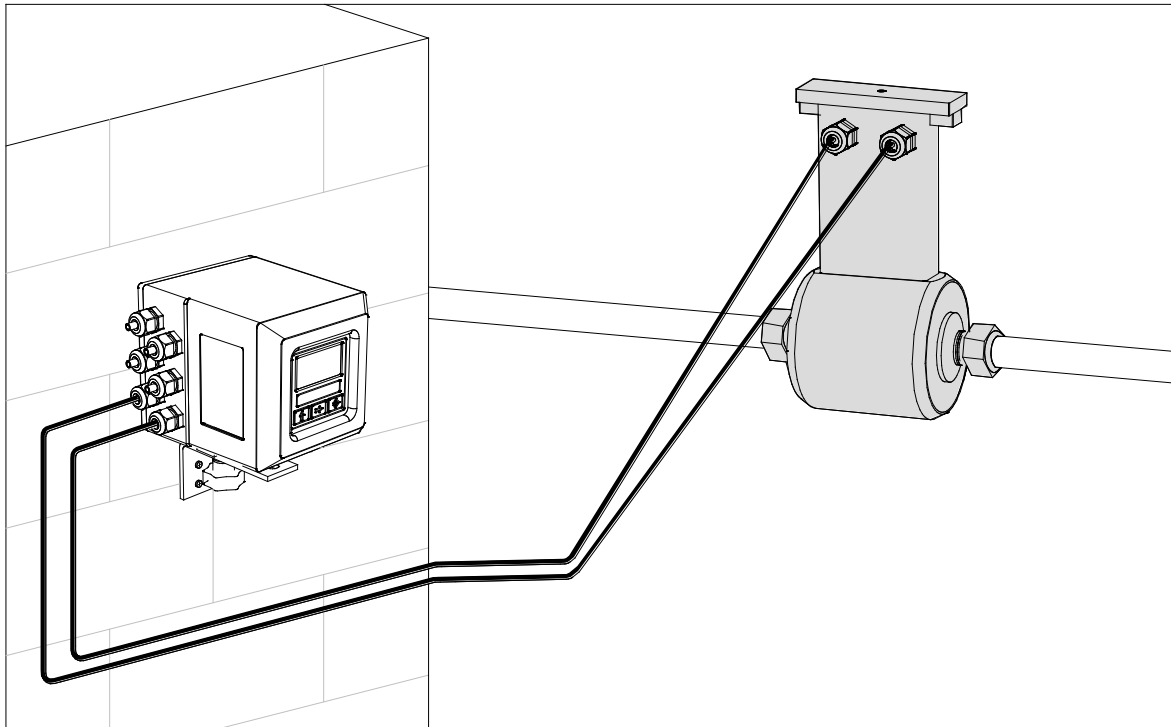
**Notes:**

- It is recommended to install the connection cables away from, or protect against sources of electromagnetic noise.
- The minimum conductivity of the liquid medium to ensure correct functionality of the empty pipe detection is 20 µS/cm

PRESSURE LOSS CALCULATION (CONES 8° ANGLES)

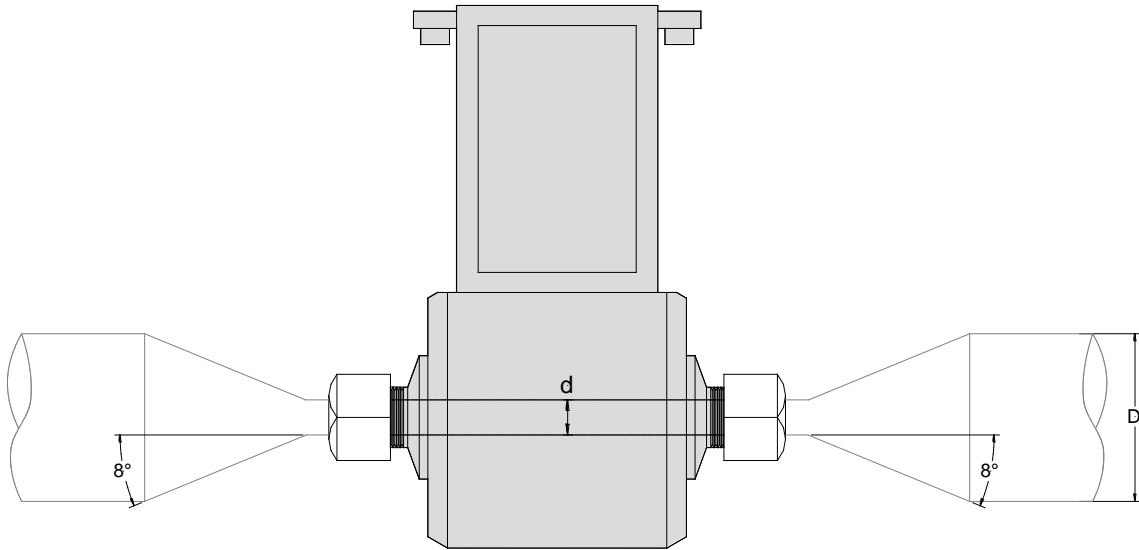

$$\Delta p = \left[0.10 + 0.20 \left(\left(\frac{d}{D} \right)^{-2} - 1 \right) \left(\frac{d}{D} \right)^4 \right] \left(\rho \frac{u^2}{2} \right)$$

Where:

Δp = Pressure loss in [Pa]

ρ = Fluid density [kg/m^3] typical value $\rho = 1000[\text{kg}/\text{m}^3]$

d = sensor diameter [m]

D = pipe diameter (greater than sensor diameter) [m]

u = Mean flow velocity in sensor diameter [m/s]

Calculation examples Δp [mbar]								
$\frac{d}{D} \backslash u$	1 [m/s]	2 [m/s]	3 [m/s]	4 [m/s]	5 [m/s]	6 [m/s]	7 [m/s]	8 [m/s]
0.5	1.1	4.3	9.6	17.0	26.6	38.3	52.1	68.0
0.6	0.9	3.6	8.2	14.6	22.7	32.7	44.6	58.2
0.7	0.8	3.0	6.8	12.2	19.0	27.4	37.2	48.6
0.8	0.6	2.5	5.7	10.1	15.7	22.7	30.9	40.3
0.9	0.5	2.1	4.8	8.6	13.4	19.3	26.3	34.3

Note :

- $\rho = 1000[\text{kg}/\text{m}^3]$ as goodness approximation of water density in common use.
- Inner diameter of sensor is used for d , express in meters.
- Indeed pressure loss equation is dimensionally correct in [Pa]. The equation results in table are show in [mbar].

HOW TO ORDER

MS 600		
EXAMPLE CODE	<i>Nominal Diameter / Lining / Maximum temperature / Measuring range</i>	
P03	P03	DN3 (1/8 "), PP lining, measuring range 0.. 10,3 / 0...259 l/h
	P06	DN6 (1/4 "), PP lining, measuring range 0...41,4/0...1036 l/h
	P10	DN10 (3/8 "), PP lining, measuring range 0..115,2/0...2880 l/h
	P15	DN15 (1/2 "), PP lining, measuring range 0.. 259,2/0...6480 l/h
	P20	DN20 (3/4 "), PP lining, measuring range 0.. 460,8/0...11520 l/h
Gasket material (internal tightness)		
1	1	O-Ring : FKM
	2	O-Ring : Epdm
	4	O-Ring : FFKM
	9	O-Ring : da specificare
Process connection type		
A	A	Male threaded UNI338 (FOR THE DIMENSIONS CONSULT THE OVERALL DIMENSIONS DRAWING)
	B	Male threaded NPT(FOR THE DIMENSIONS CONSULT THE OVERALL DIMENSION DRAWING)
	Z	Gasket material: to be specified
Number and electrodes material		
2	2	n. 4 (2 measure + 2 for ground) electrodes in AISI 316
	4	n. 4 (2 measure + 2 for ground) electrodes in Hastelloy C
	5	n. 4 (2 measure + 2 for ground) electrodes in Titanium
	6	n. 4 (2 measure + 2 for ground) electrodes in Tantalum
	7	n. 4 (2 measure +21 for ground) electrodes in Platinum
	0	Electrode material: to be specified
Execution / Protection rate		
A	A	Compact execution, IP67 protection rate
	B	Separate execution , maximum length 20m, remember to added the cables cost , protection rate IP68 (standing immersion with 1,5 m of head water)
	F	Execution separate with N° 2 connectors IP 68 suitable for C015/16 for fast cable connections (max 20 m-ADD THE COST)
	G	Execution separate with N° 1 connectors IP 68 suitable for C018 for fast cable connections (max 20 m-ADD THE COST)
	M	Compact execution, IP67 protection rate , with the possibility to turn the converter of 90°



MS600-P03-1A2A (Complete code example for order)

The manufacturer reserves the right to make design improvements without notice.